

This user guide is for controllers with the software version 2.0.0 or newer.

APPLICATIONS

The controller can control 0...10 V controlled actuators and thermal actuators or 3-point actuators. See the following figure for an application example.

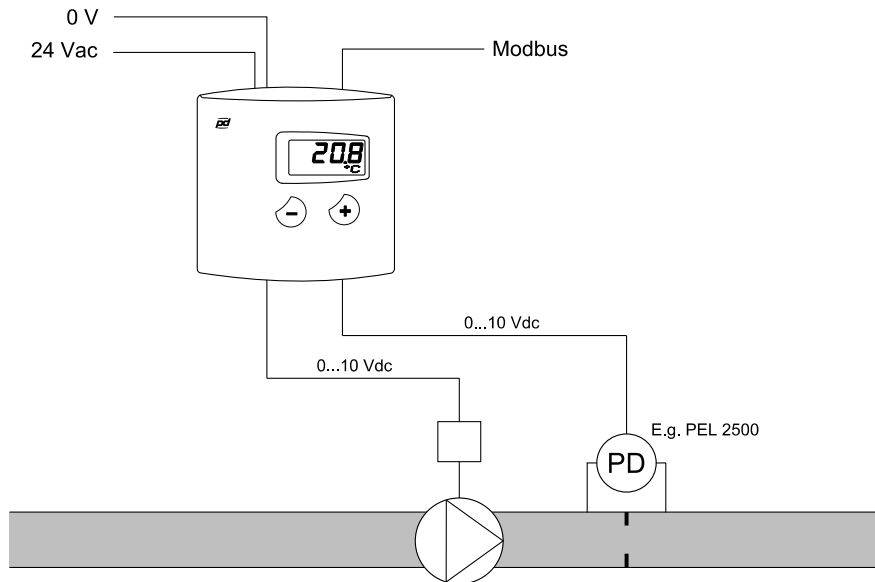

COMMISSIONING

WIRING



Device wiring and commissioning can only be carried out by qualified professionals. Always make the wirings while the power is switched off.

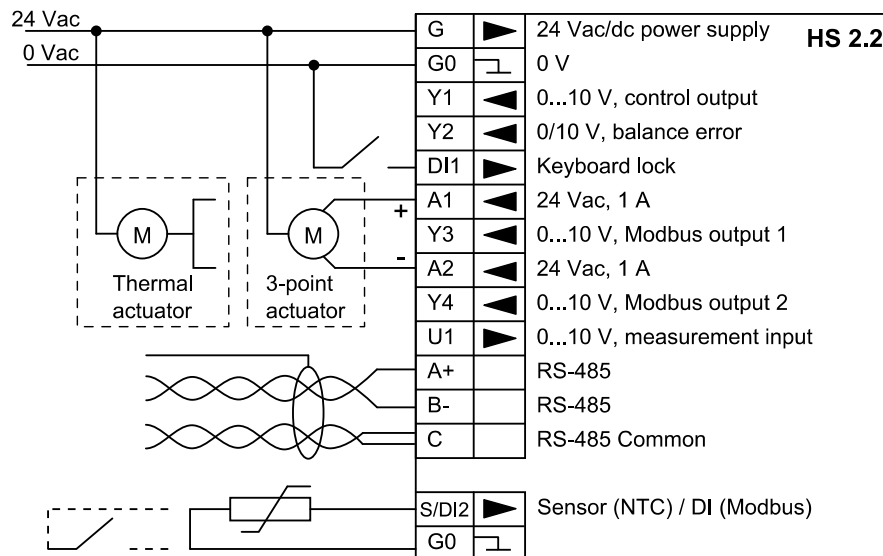

NOTE: The 3-point actuators are controlled to the extreme position when the power is switched on. The procedure takes few minutes to complete.

NOTE: The S/DI2 information (temperature measurement / digital input) can only be read via Modbus. Accordingly, the Y3 and Y4 outputs can only be controlled via Modbus.

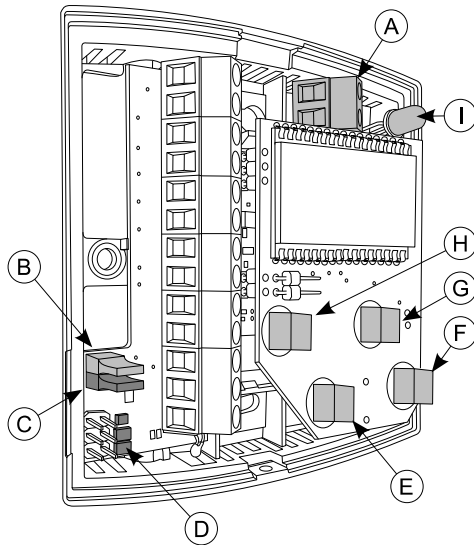

- A. Terminals for NTC 10 sensor or DI contact
- B. Bus termination (120 Ω)
 - o closed = terminated
 - o open = no termination
- C. Configuration mode selector
 - o closed = configuration mode
 - o open = user mode (factory setting)
- D. Indicator lights
 - o green PWR = supply OK
 - o yellow TX = transmission from controller
 - o yellow RX = bus activity
- E. M button
- F. OK button
- G. + button
- H. - button
- I. Indicator light
 - o green = OK
 - o red = alarm

Menu

Menu is activated by setting the configuration mode selector to the closed position. You can proceed in the menu by touching the “M” and “OK” buttons. The values can be changed with the “+” and “-” buttons. The value is accepted with the “OK” button. The following menu structure contains the factory settings.

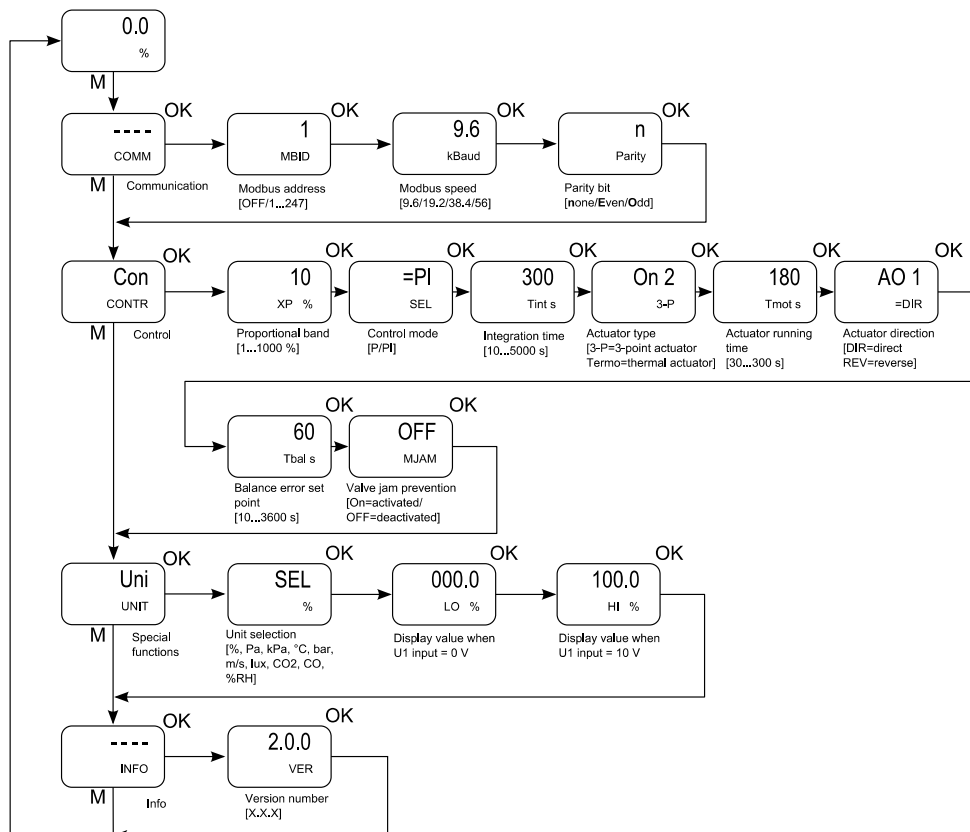

Balance error

The balance error output (Y2) activates (-> 10 V) if the controller doesn't reach the balance during the set time. The balance error time set point (10...3600 s) can be adjusted with the Tbal s parameter. The default value is 60 s.

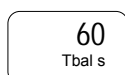

Selecting the unit

0...10 V input signal is possible to scale according to the different units. Default unit is a percent [%], but can be scaled to following units; Pa, kPa, °C, bar, m/s, lx, CO₂, CO and % rH.

Internal measuring range of the controller is 1000 and single step is one. The minimum and maximum of measuring range can be adjusted [-9999...9999].

NOTE: Single step is different if measuring range is scaled.

Example: Using a differential pressure transmitter (e.g. Produal PEL 2500) with HS 2.2-M

The differential pressure transmitter measuring range is set to 0...500 Pa.

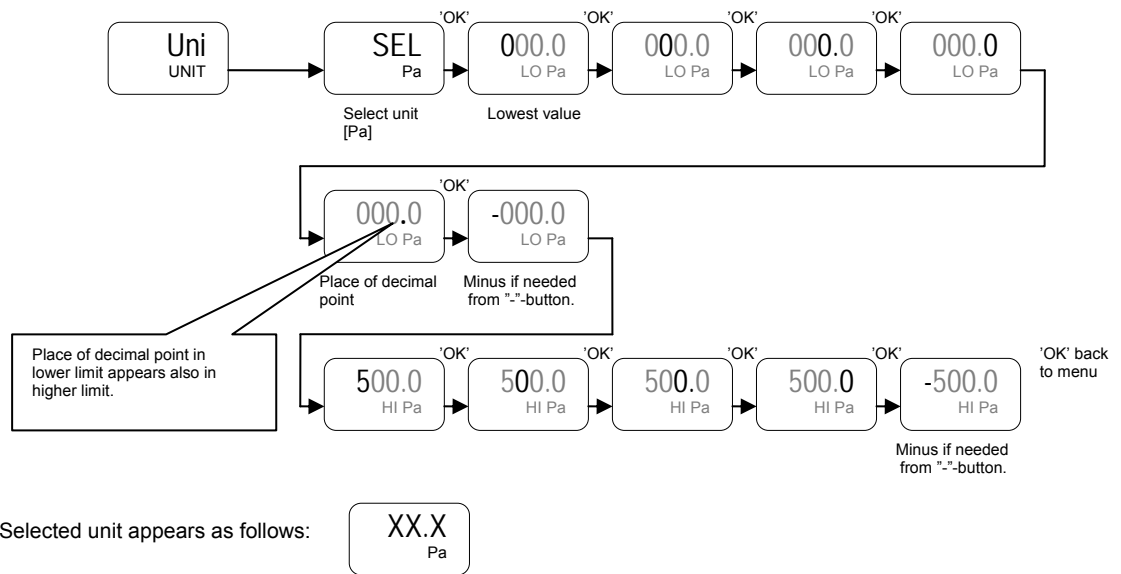

USER MODE

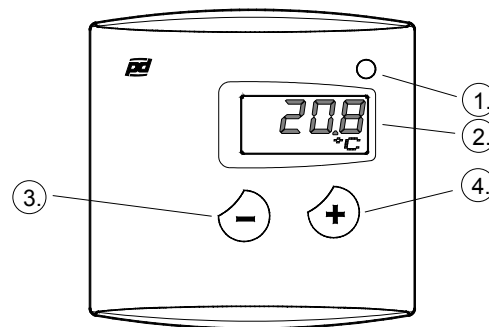

1. Status LED
 - Green = normal
 - Red = Balance error
2. LCD display
Displays the U1 input that is scaled for the wanted unit.
3. Setpoint adjustment
4. Setpoint adjustment

MODBUS

Bus properties

Protocol	RS-485 Modbus RTU
Bus speed	9600/19200/38400/56000 bit/s
Data bits	8
Parity	none/odd/even
Stop bits	1
Network size	up to 247 devices per segment

Bus termination

The Modbus can be terminated by placing the Modbus termination jumper.

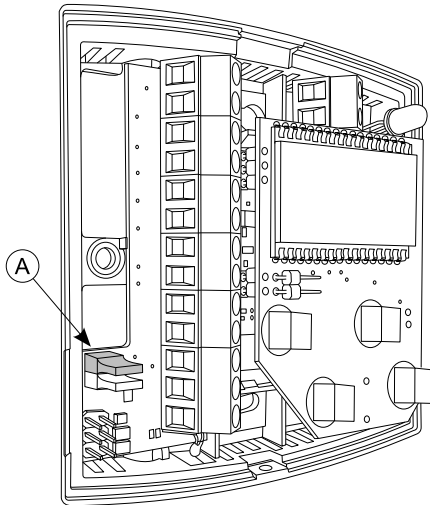

A. Modbus termination jumper

Supported Modbus functions

0x01	Read Coils
0x02	Read Discrete Inputs
0x03	Read Holding Registers
0x04	Read Input Registers
0x05	Write Single Coil
0x06	Write Single Register
0x0F	Write Multiple Coils
0x10	Write Multiple Registers
0x17	Read/Write Multiple Registers

Modbus registers

Data type:

bit	= 0 or 1
unsigned	= unsigned integer (0...65535)
signed	= integer (-32768...32767)

NOTE: The memory durability is 1000000 write cycles.

The controls marked with * are stored in the volatile memory. These controls are returned to factory defaults after a power failure.

Coils (read / write)

Register	Parameter description	Data type	Value	Range	Default
1	*Controller output overdrive enable (Y1)	bit	0...1	0=off, 1=on	0
2	*Balance error output overdrive enable (Y2)	bit	0...1	0=off, 1=on	0
3	*Actuator output overdrive enable (A1/A2)	bit	0...1	0=off, 1=on	0
4	*Controller operating mode (PI/P)	bit	0...1	0=PI, 1=P	0
5	Valve jam prevention function	bit	0...1	0=off, 1=on	0
6	Actuator operating mode (Thermal/3-point)	bit	0...1	0 = thermal actuator, 1 = 3-point actuator	1
7	Actuator direction reversed	bit	0...1	0=off, 1=on	0

Discrete inputs (read only)

Register	Parameter description	Data type	Value	Range
10001	Display lock status	bit	0...1	0=no, 1=yes
10002	DI2 input status	bit	0...1	0=off, 1=on

Input registers (read only)

Register	Parameter description	Data type	Value	Range
30001	Discrete inputs (16 - 1)	unsigned	16 bits	16 bits
30002	Coils (16 - 1)	unsigned	16 bits	16 bits
30003	Ambient temperature	signed	-600...600	-60.0...60.0 °C *)
30004	External temperature measurement (S/DI2)	signed	-600...600	-60.0...60.0 °C *)
30005	U1 input value	signed	0...1000	0...10.00 V

Holding registers (read / write)

Register	Parameter description	Data type	Value	Range	Default
40001	Set point	signed	0...1000	0.0...100.0 %	500
40002	*Controller output overdrive by Modbus (Y1)	signed	0...1000	0...10.00 V	0
40003	*Balance error overdrive by Modbus (Y2)	signed	0...1000	0...10.00 V	0
40004	*Voltage output value (Y3)	signed	0...1000	0...10.00 V	0
40005	*Voltage output value (Y4)	signed	0...1000	0...10.00 V	0
40006	*Actuator output value (A1/B1)	signed	0...1000	0.0...100.0 %	0
40007	Proportional band	signed	0...1000	0...1000 %	10
40008	Integration time	signed	10...5000	10...5000 s	300
40009	Actuator running time	signed	30...300	30...300 s	180
40010	Display unit	signed	0...9	0 = % 1 = Pa 2 = kPa 3 = °C 4 = bar 5 = m/s 6 = lux 7 = CO ₂ 8 = CO 9 = % rH	0
40011	Display scaling, U1 = 0 V	signed	-9999...9999	-9999...9999	0
40012	Display scaling, U1 = 10 V	signed	-9999...9999	-9999...9999	1000
40013	Numbers after decimal point	signed	0...3	0...3	1
40014	Balance error set point	signed	10...3600	10...3600 s	600

*) Normal operating range